

\$The Solution

Pay Your Bills Quickly and Efficiently!

Banking/Bill Pay Kiosks

While online bill payments are convenient, much of its transactions are driven more by the upper and middle-class customers. A caveat is that the unbanked and the underbanked are not being serviced to this convenience. That particular demographic usually pays with cash or check and in most cases has to go directly to a service center to wait in line to pay a bill. This could pose problems such as delayed payments and higher staffing costs for customer service employees.

With the use of a Financial kiosk, all these issues are covered. Parabit kiosks can accept cash and checks, and credit cards to provide customer convenience. Kiosks can also be located not only in service centers to ease the heavy foot traffic, but also in remote locations.

Parabit partners with software companies to provide a turn-key Financial Kiosk Solution. With the Quick Deposit/Bill Payment kiosk, your system can be integrated so that your customers can approach the kiosk with a user-friendly interface. Pay bills easily with a check, credit card, cash or make deposits. Kiosks can also accommodate different languages to service an array of demographics. In addition, kiosks can be integrated to include teleconferencing, which supports the needs of the clients.



Poseidon

Queuing Kiosks

Do you have a busy waiting room? Parabit's Queuing Kiosks help manage the flow of clients through busy lobbies. Queuing Kiosks give your clients a more personal experience as they can serve as a virtual assistant. The client checks in at the kiosk and is placed in the right que by answering a few analytical questions. Once the right que is established, the client receives a ticket with the que number. The kiosk can direct the client to a refreshment station or to take a survey. This is beneficial for organizations which may need up-to date information in their database.

The kiosk may also be integrated with a digital screen which showcases the que number and advertisements. The digital screen not only serves as a source of information but can also provide revenue generating streams. The interaction with the kiosk is then turned from wasted waiting time into a valuable experience for both the client and the organization.



Ares



Helius

Ares

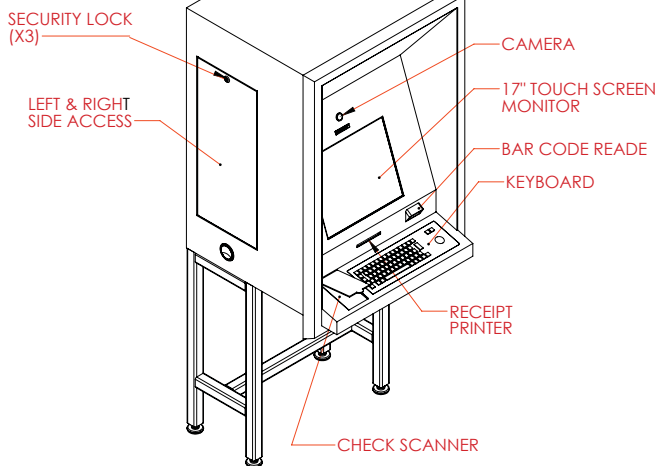

Helius

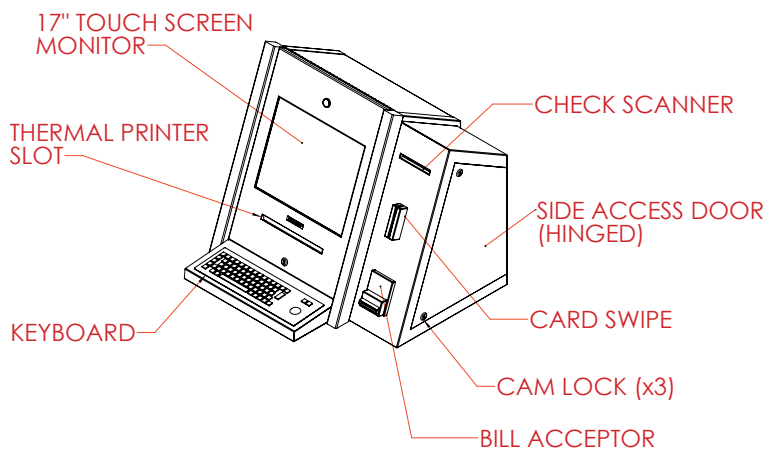

Poseidon

