

Model 900 Remote Drive-Thru System

ComCo's 900 drive-thru system has fewer moving parts, requiring less maintenance for less downtime.

Model 900 Remote Drive-Thru System

4" x 7" clear tube provides less obstruction between operator and customer

Touch sensitive switches provide a weatherproof environment for electrical components and an exceptionally long switch life

Powder coated finish provides environmental durability and long-term product beauty

Optional Customer Video Module with high contrast 10" LCD Monitor

The handy Tip-tube places the large 4" x 7" carrier within easy reach of the customer

TRANSPORT COMMERCIAL OR RETAIL TRANSACTIONS WITH ONE SIMPLE, FAST AND ECONOMICAL SYSTEM

The ComCo Model 900 is perhaps the most flexible pneumatic system ever produced. It is the result of many years of research into pneumatic tube application and design.

With over 40 years of experience in pneumatic tube installations the ComCo 900 system performs as the most versatile and economical approach to today's drive-in needs.

- **Integrated electrical system.**
- **Modular mechanical system.**
- **Innovative audio and video system.**
- **Optional, new slimline Customer Video Module with new and improved 10" LCD monitor.**

* Integrated audio and video communication systems available with all packages.

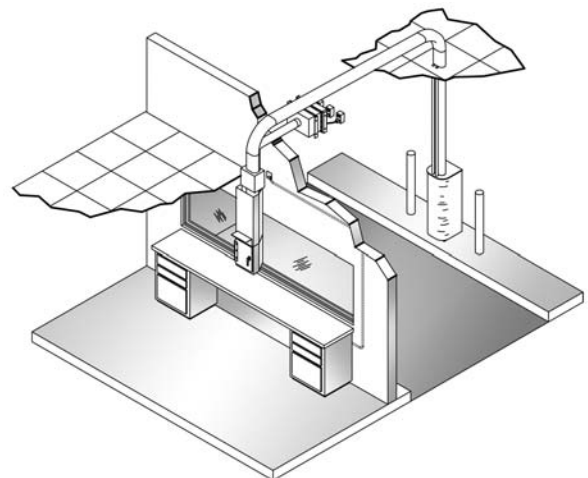

Integrated Solutions is ComCo's exclusive series of modular products that seamlessly integrate into a highly-productive backroom teller center.

*Equipment design subject to change without notice.

INNOVATION AT WORK.

Model 900 Remote Drive-Thru System

Integration At Work...

The 900 system combines versatility and function. By using a ComCo designed removable 4" x 7" carrier, the Model 900 system has a faster speed of operation. Also, the system has fewer mechanical components therefore requiring less service and maintenance.

Model 900 Customer Unit

- Faster air system increases productivity and customer satisfaction. The ComCo 900 system can transport two transactions by the time a slow, mechanical conveyor can transport one.
- Easier to operate with convenient touch sensitive "CALL" and "SEND" switches.
- The ComCo 900's modular design enables easy maintenance and service, if needed.
- A unique blower design makes it possible to power remote locations over 500 feet away.
- The 900 system is SUPER quiet since the blower is generally located in the canopy away from the customer or operator units.



Unique Carrier Design



Our research shows that most commercial transactions average less than one pound yet they are too bulky to fit into a small 4" or 4 1/2" retail carrier. The unique ComCo 900 carrier design allows for easy insert and retrieval of bulky transaction by customers and operators. The carrier is light weight, fully accessible and easier to use than the small retail carriers and can hold 3 times the load. They are constructed in such a way that it provides a handy flat writing surface for customer use.

Model 900 Operator Unit



- The Model 900 Operator unit requires no counter space. The unit was designed to be suspended from the ceiling, clear of the countertop.
- Heavy, clear acrylic door gives visual indication of carrier arrival.
- Heavy duty, chrome plated latch assures complete sealing of the pneumatic tube system.
- Indicator light inside unit Glows when the doors on the Customer unit and the Operator unit are closed.

Model 521 Options and Accessories



CVM 1000
Optional
Customer
Video Module
with high
contrast 10"
color LCD
Monitor



Dual-Side
Operator Unit
provides dual
access, dual
control terminals,
designed for use
by two or more
operators.

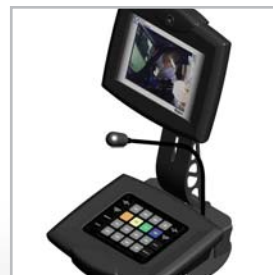

CCS-1561
Optional
Audio/Video
Station for 1 to 16
lanes provides
exceptionally clear
audio and video
and with a high
contrast 6.4" color
LCD Monitor

*Equipment design subject to change without notice.

INNOVATION AT WORK.